

**MD□-30 Series**

- Direct Drive Brushless AC Servo
- 30mm diameter, 3 stack lengths
- Incremental or absolute encoder feedback

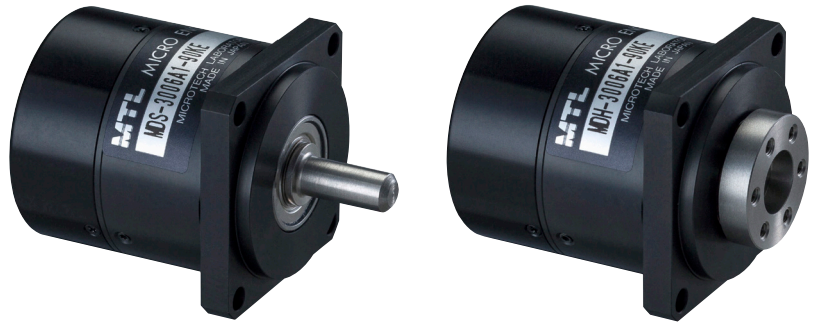

Visit [nipponpulse.com](http://nipponpulse.com) to download 3D CAD drawings and 2D prints of this motor.

Specifications	Unit	MDS-3006	MDH-3006	MDS-3012	MDH-3012	MDS-3018	MDH-3018
Peak Stall Torque	Nm	0.14		0.28		0.42	
Rated Torque	Nm	0.060		0.095		0.13	
Continuous Rated Torque	Nm	0.044		0.068		0.10	
Max Speed	rpm	1000					
Rated Speed	rpm	1000					
Max Encoder Resolution	P/R	Incremental: 432,000 (multiplied by 4) / Absolute: 524,288 (19 bit)					
Input Power (driver input)	VDC	48					
Peak Power	W	15		20		30	
Peak Power Rate	kW/s	31	23	71	60	110	98
Peak Armature Current	Arms	4.6		5.6		6.3	
Rated Armature Current*	Arms	1.8		1.8		1.7	
Voltage Constant	V/krpm	2.8		4.5		6.8	
Torque Constant (at 25°C)	Nm/Arms	0.026		0.043		0.065	
Line Armature Resistance (at 25°C)	Ω	2.1		2.3		2.5	
Line Armature Inductance	mH	1.0		1.3		1.5	
Rotor Poles	P	16					
Moment of Inertia (J)	g•cm <sup>2</sup>	6.45	8.86	11.2	13.6	15.9	18.3
Permissible Radial Load (Fr)	N	94					
Permissible Axial Load (Fa)	N	47					
Mass	kg	0.13		0.16		0.18	
Operating Environment		0°C - +40°C, 10% to 85% relative humidity (non-condensing)					
Standard Heatsink		120 x 120 x 8 Aluminum					

\* Rated armature current is the value measured with the standard heatsink attached to the motor at an ambient temperature of 40°C.

Encoder Options	Base Resolution	Interpolation Factors	Max. Resolution (post quad)
Incremental	3375	2, 4, 5, 8, 10, 16, 20, 32	432,000
Absolute (single turn)	19-bit	BiSS-C format	524,288

## MDS-30XX Dimensions

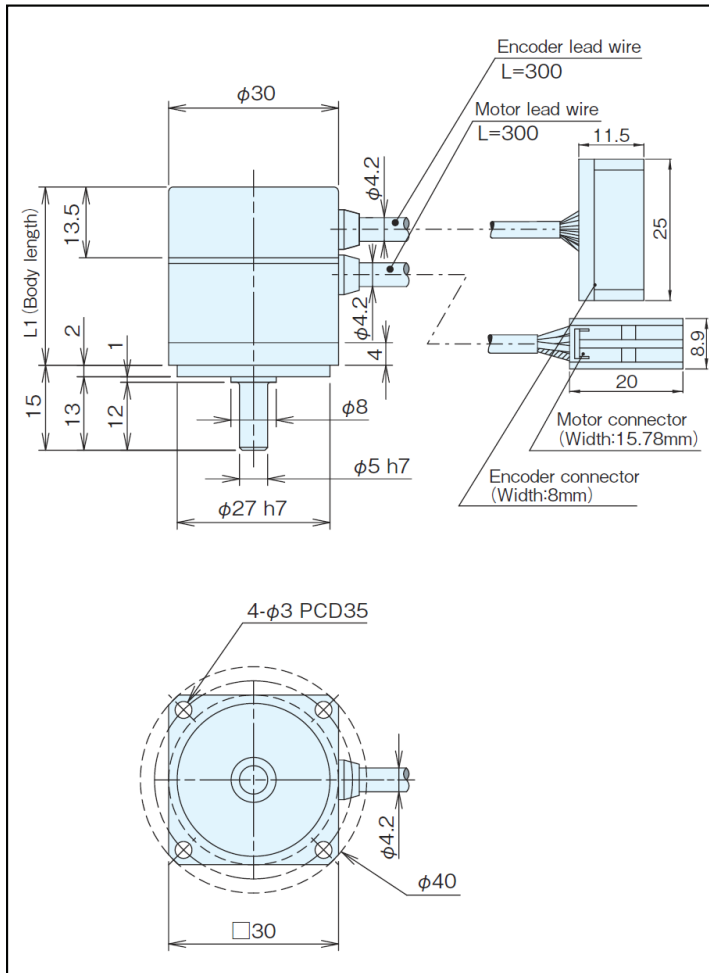

## MDH-30XX Dimensions

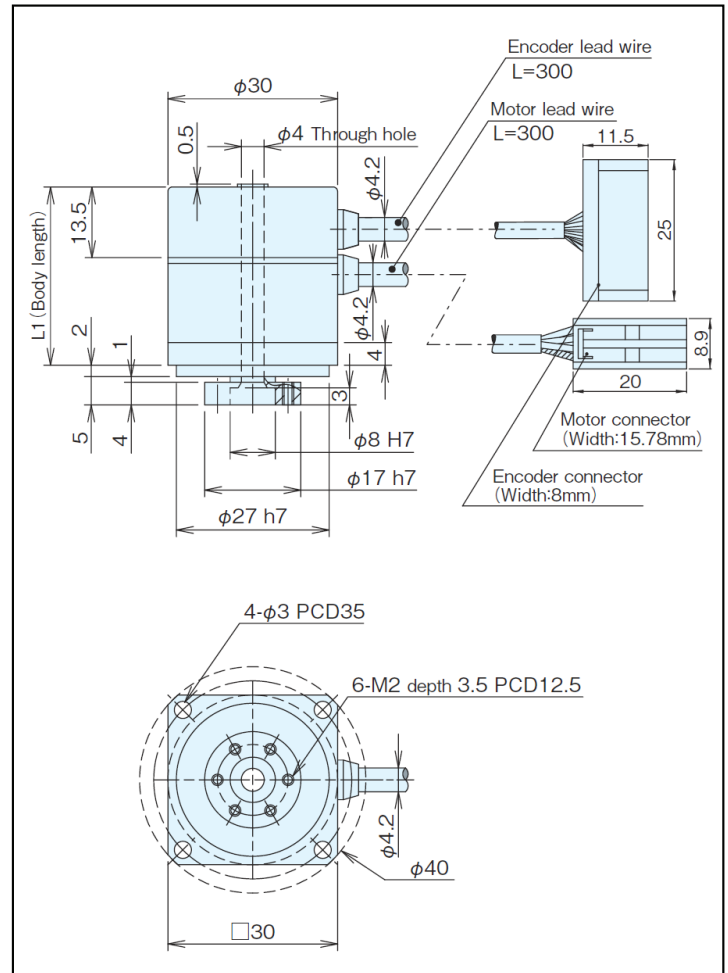

## Standard Models

- MD□-30△-108KE (Incremental)
- MD□-30△-19B (Absolute)

□ = shaft configuration      △ = stack length indicator  
 S = solid shaft, H = hollow shaft      06, 12, 18

Model	Stack Length (L1)
MD□-3006	31.5 mm
MD□-3012	37.5 mm
MD□-3018	43.5 mm

see drawings of motor dimensions on next page

## Performance Curves

### MD□-3006

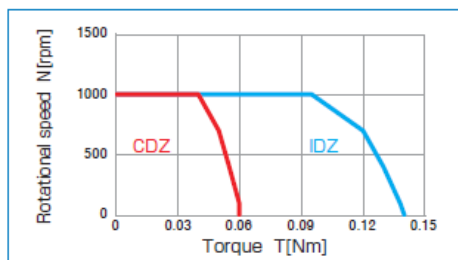

### MD□-3012

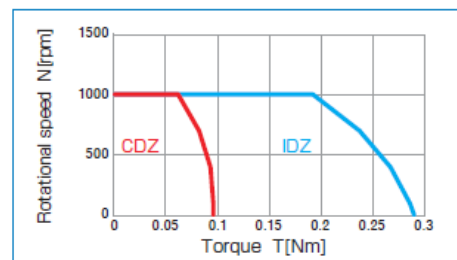

### MD□-3018

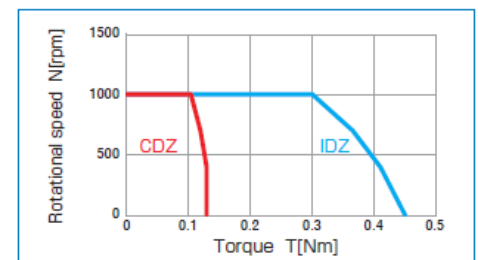

CDZ = Continuous Duty Zone, IDZ = Intermittent Duty Zone

Performance curve based on MCC Drive, 48VDC input power

For assistance in selecting the best motor for your application, contact Nippon Pulse to speak with an applications engineer. 1-540-633-1677